

SPYPER

ATOL

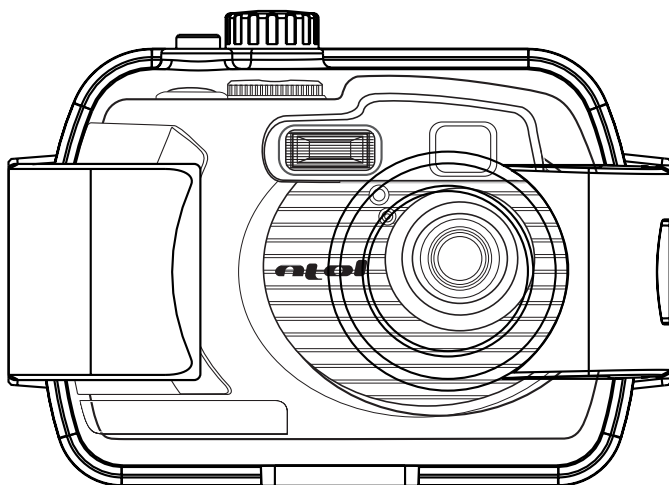

User's Manual

Product Overview

1. Flash
2. Battery door/SD or MMC card slot
3. Lens
4. Self-timer LED
5. Viewfinder

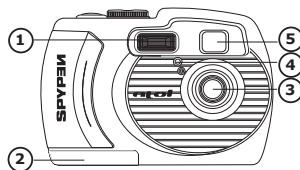

1. Viewfinder
2. Operation LED
3. LCD screen
4. Display button
5. Left/Self-timer button
6. Menu button
7. OK/Flash button
8. Down/Zoom out button
9. Right/Continuous mode button
10. Up/Zoom in button
11. Power button
12. Buzzer hole

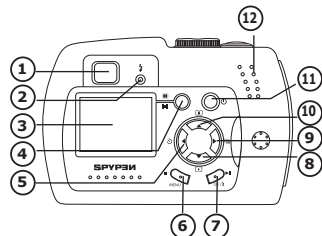

1. Normal/Macro selector
2. Port for USB/Video Cable/DC in terminal

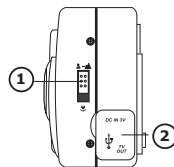

1. Hand Strap Holder

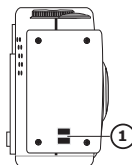

1. Shutter button
2. Mode selector

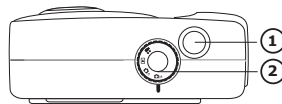

1. Underwater viewfinder
2. Hinge lock

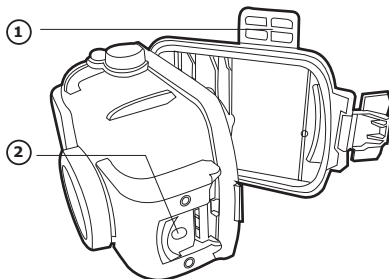

Table of Contents

1 Getting Started	4
• What can I do with my Camera?	4
• What can I do with my Digital Pictures?	4
• What can I do with my Video Clips?.....	4
• Camera Package Contents.....	4
• Attaching the Hand Strap.....	4
• Installing the Batteries	5
• Turning the Camera On and Off	5
• Power Save Setting.....	5
• Checking the Battery Level	6
• Connecting AC Adaptor (not included)	6
2 Camera Setting	6
• Checking Camera Status.....	6
• Camera Mode	7
• Turning the Information Display LCD Screen Off.....	7
• Turning the Beep Sound On and Off	7
• Setting the Display Language	8
• Setting the Current Date and Time.....	8
3 Taking Pictures	8
• Taking a picture.....	8
• Taking Macro Picture	9
• Taking Continuous Pictures.....	9
• Setting the Flash Mode	9
• Setting Quick View.....	9
• Setting the Picture Resolution.....	10
• Setting the Picture Quality	10
• Setting Self-timer	10
• Digital zoom	11
• Setting Exposure Compensation	11
• Setting White Balance	11
4 Recording Video Clips	12
• Recording Video Clips.....	12
5 Playback Pictures and Video Clips.....	12
• Playing Pictures	12
• Playing the Video Clip.....	13
• Protect the Picture(s) or Video Clip(s) Against Deletion	13
• Deleting Picture(s) or Video Clip(s) from the Camera	13
6 Using the Camera under Water	14
• Using the Rubber Ring.....	15
• Assemble Waterproof Case.....	15
7 Using SD/MMC Card	16
• Using the SD(Secure Digital) Card or MMC(MultiMediaCard) Card	16
• To Format a Memory Card	16
• Copy Internal Memory Pictures to a Memory Card	17
• DPOF(Digital Print Order Format).....	17
• P.I.M.(PRINT Image Matching).....	18
8 Installing the Software onto a Computer	18
• Installing the software.....	18
• Software included with your camera	19
• Computer system requirements	19
9 Transferring Pictures, Video Clips To Your Computer.....	20
• Before you transfer pictures	20
• Connecting to your computer	20
• Transferring and Viewing the Pictures and Video clips	20
• Connecting to a TV	20
10 Troubleshooting Problems	21
• Troubleshooting	21
11 Getting Help.....	22
• Online Services	22
• Customer Support	22
• ArcSoft Software Help	22
12 Appendix	23
• Technical Specifications	23
• Using your batteries.....	24
• Tips, Your Safety & Maintenance	24
• Uninstalling the camera driver	25
• Regulatory Information.....	25

1 Getting Started

• What can I do with my Camera?

Capture



Enjoy point & shoot operation. Store pictures, video clips to the internal memory or a SD/MMC card.

Set Up



Select various camera and video recording settings.

• What can I do with my Digital Pictures?

View



View pictures on the LCD screen or on a computer using the Arcsoft® software supplied.

Save



Save pictures to the computer memory by Mass Storage interface.

Communicate



Send the pictures over the Internet to family and friends.

• What can I do with my Video Clips?

Playback



Playback video clips on a computer using the Windows® Media Player or other Media software supplied.

Save



Save video clips to the computer memory by Mass Storage interface.

Communicate



Send the video clips over the Internet to family and friends.

• Camera Package Contents



ATOL



Waterproof Case



Warranty Card

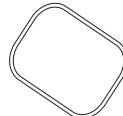

Rubber Ring

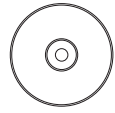

The CD-ROM includes
My Digital Cam Driver (PC)
ArcSoft Software Suite (PC & Mac)
Adobe Acrobat Reader (PC & Mac)
User Manual in PDF format



Quick Guide



Hand Strap
(for camera)



Rubber Strap
(for waterproof case)



Coating Grease

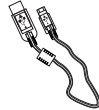

USB Cable



TV Cable



2 x AA Alkaline
Batteries

• Attaching the Hand Strap

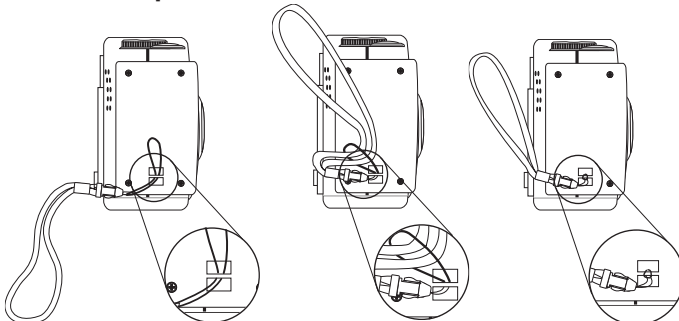

● Installing the Batteries

2 x AA Alkaline batteries are supplied with the product. For more guidelines on battery usage, please see **Using your batteries.**

1. Open the camera battery door by pushing it outwards as illustrated.
2. Insert the batteries as shown, ensuring you follow the +/- signs correctly.
3. Close the battery door by pushing it down and then slide it towards the camera to lock.

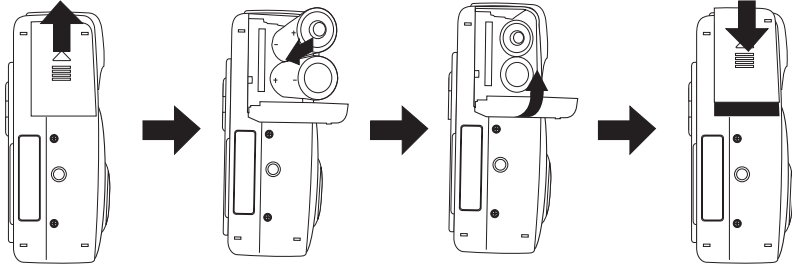

NOTE:

You can use either 2 X AA batteries or an AC adaptor (DC3.3V, not included) to supply power for the camera.

● Turning the Camera On and Off

Fully press and hold the Power button until the operation LED turns green and the LCD is on. Press and hold the Power button again to turn off the camera.

NOTE:

- It takes about 2 seconds to power up the camera.
- When powering on the camera in Auto/Manual/Video mode, the date will display on the bottom right corner of the LCD screen for one second. Then it changes to time for one second, after that the date and time indicator will be off.

Operation LED Power button

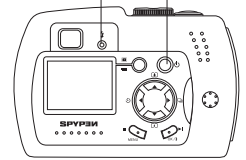

● Power Save Setting

Your camera is designed to turn off LCD screen and the camera automatically after a period of inactivity to save battery life. You can change Power Save Setting by the following steps.

1. Turn the camera on.
2. Press Menu button.
3. Press the Right button to select "SETUP MENU".

Press ▲▼ to select "POWER SAVE".

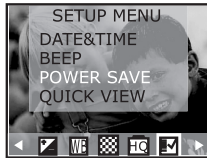

Press ▲▼ to select item.



The function for each setting is:

One minute: This camera will automatically turn off the LCD screen after one minute of inactivity (the operation LED will flash.) Press any button will reactivate the LCD screen. After the above 1 minute power saving, if there is no more operation in another one minute, the camera will automatically power off. You need to press the Power button if you want to turn on the camera again.

Three minutes: This camera will automatically turn off the LCD screen after three minutes of inactivity (the operation LED will flash.) Press any button will reactivate the LCD screen. After the above three minutes power saving, if there is no more operation in another one minute, the camera will automatically power off. You need to press the Power button if you want to turn on the camera again.

Off: This camera will not perform the power saving function.

NOTE:

- Power save setting is available in all camera modes.
- Auto power off is automatically disabled while the AC adaptor is connected to the camera.

● Checking the Battery Level

Check the battery level by pressing Display button before taking pictures.

1. Turn the camera on.
2. Check the battery level that appears on the LCD screen.

NOTE:

- The battery level indicator only appears on the LCD screen for around 5 seconds each time.
- You can check the battery level anytime by pressing Display button.



- Batteries have adequate power.
- Battery power is low.

Please note that when the batteries need to be replaced, a warning "REPLACE BATTERY!" will show on LCD screen and the camera will automatically turn off.

● Connecting AC Adaptor (not included)

Connect the adaptor into the DC-In terminal (DC-IN 3.3V) as shown to power the camera from a household power outlet.

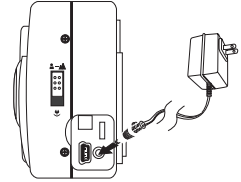

NOTE:

- Please make sure that you use an AC adaptor with the correct specification for the camera (DC3.3V).
- Please be sure to turn off power before connecting or disconnecting the Adaptor.
- The camera automatically switches over to AC adaptor powered operation whenever the AC adaptor is plugged into the camera.
- Recommend using the AC adaptor to power the camera whenever connected to a computer.

2 Camera Setting

● Checking Camera Status

Switch the camera on, view the camera LCD screen to check which camera settings are active. If feature icon is not displayed, that particular feature is not activated.

Video Mode	Playback Mode	Auto Mode	Manual Mode
 2002/12/23	 100_0007 02/12/23	 x1.0 2002/12/23	 x1.0 2002/12/23
Picture Quality	Camera Status		Other Features
L: 1600X1200 F: Fine	AWB Auto white balance 7 The number of pictures taken 14 Pictures remained	Record mode Macro mode Take single picture Continuous pictures SD card inserted	10s self-timer 2s self-timer Auto flash mode Flash mode on Flash mode off Red eye Video mode
L: 1600X1200 N: Normal			
S: 800X600 F: Fine			
S: 800X600 N: Normal			
	Full	Low	

● Camera Mode

The camera has four working modes. You can select the mode you prefer using the Mode selector located on the top of the camera.

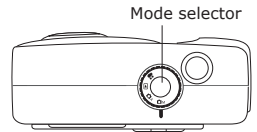

Auto mode A

Under this mode, the camera will automatically judge the environment conditions for you. It will set the Exposure and White balance automatically according to the shooting environment.

Manual mode M

Under this mode, you can set the Exposure and White balance based on different environment condition before taking pictures. (Further detail refers to **Setting Exposure Compensation** and **Setting White Balance**)

Playback mode ▶

Playback or delete pictures/video clips from the camera.

Video mode ▶

Using this mode to record video clips.

● Turning the Information Display/LCD Screen Off

To turn the information display off, just simply press the Display button once, press it again will turn off the LCD screen. Press the Display button one more time will turn on the information display and the LCD screen.

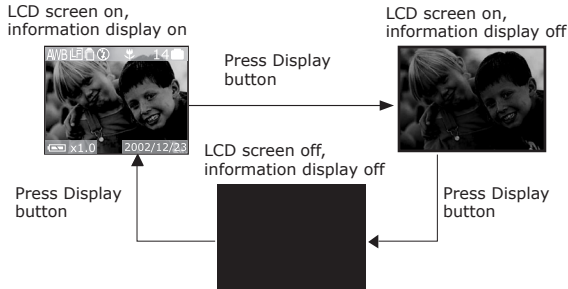

● Turning the Beep Sound On and Off

You can turn the beep sound on and off in any camera mode. When the Beep sound is turned on, the camera will beep when you press the buttons.

1. Turn on the camera.
2. Press Menu button.
3. Press the Right button to select "SETUP MENU .

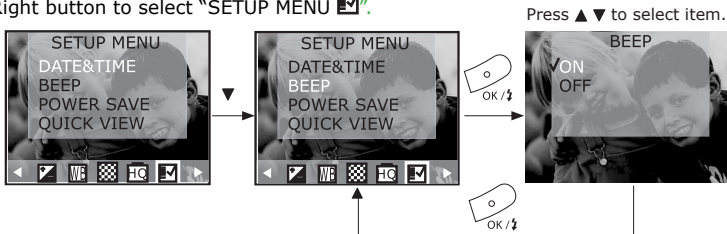

NOTE:
The default setting is "On".

● Setting the Display Language

Under this setting, you can select the language you prefer for the LCD screen. You may change the language setting in any camera mode.

1. Turn on the camera.
2. Press Menu button and use Right button to select "SETUP MENU .

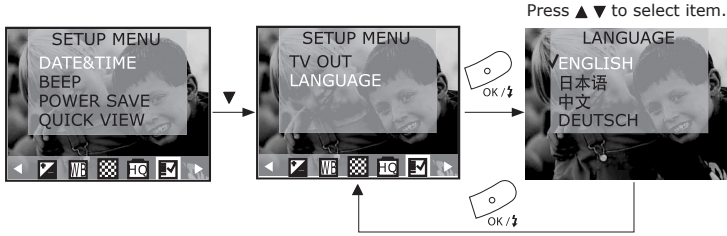

● Setting the Current Date and Time

1. Turn the camera on.
2. Press Menu button and use Right button to select "SETUP MENU .

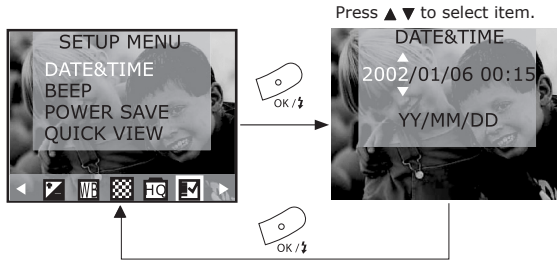



Use Up/Down button to change the display of date as:

- A. YY/MM/DD
- B. MM/DD/YY
- C. DD/MM/YY

3 Taking Pictures

Before you take pictures, please read this note first:

 **NOTE:**
Never remove batteries, disconnect the AC adaptor from the camera, or unplug the adaptor while a picture is being saved. Doing so will prevent the current picture being saved and may corrupt other pictures already stored on the camera's internal memory or on a memory card.

 **NOTE:**
When taking outdoor pictures, avoid intense sunlight that may cause sun spots in pictures. And always make sure that the sun or other light source is in front of the subject.

● Taking a Picture

1. Set the Mode selector to Auto or Manual mode.
2. Turn on the camera.
3. Frame your subject using the LCD screen.
4. Press the Shutter button completely down to take a picture. Hold the camera steady. A beep will sound when the picture has been taken.

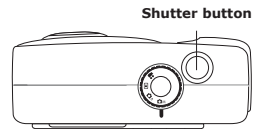

 **NOTE:**

- In Manual mode, while capturing a picture, you can press the Shutter button halfway down to check whether there is proper exposure value subject to your current light condition for capturing.
- When the camera has automatically completed the setting of exposure and white balance, the icons on the LCD screen will turn green.
- When the camera's auto exposure and auto white balance function is not ready or your capturing condition is over the camera's setting, the icons on LCD screen will turn red.
- Under the above condition, if you still take the picture, the picture taken is in risk of over exposure or too dark.

● Taking Macro Picture

Usually we set the Normal / Macro Selector to Normal  when the subject is 20 inches to infinity. For subjects within 8 ~ 20 inches, set the selector to Macro .

NOTE:

- The flash is set to "Flash Off" when the Macro is activated except flash setting is set to "Flash on".
- Users can change the flash setting to "Flash on" by pressing Flash button. But the Flash Auto and Red-Eye Reduction setting is not available if Macro mode is selected. They are only available in Normal mode.

● Taking Continuous Pictures

The camera will record pictures continuously at the speed of approximate 3 pictures per shot.

1. Turn the camera on.
2. Set the Mode selector to Auto or Manual.
3. Press the Continuous Mode button to activate Continuous mode.
4. Be sure that icon  appears on the LCD screen, then press Shutter button.

Press the Continuous Mode button again to cancel Continuous mode function.





NOTE:

- The number of continuous pictures you can take will depend on the available memory and resolution settings.
- In continuous mode, can take 3 pictures per shot





● Setting the Flash Mode

1. Turn the camera on.
2. Set the Mode selector to Auto or Manual.
3. Press  button to cycle through the Flash Mode until the one you want is shown on the LCD screen.

The camera has four flash modes. Different flash setting applied to different situation:

-  Flash Mode on, the flash fires for every picture. Use this setting in high-contrast situations to provide fill-light or use it indoors in low light.
-  Flash Mode off, the flash does not fire. Use this setting for outdoor pictures or where flash is prohibited or may be distracting. Also use when shooting toward a reflective surface, such as a window or mirror. If you do not have enough light when using this setting, your pictures will be too dark.
-  Auto Flash Mode, the flash fires automatically as needed. Use this setting to take most pictures.
-  Red eye, Use this setting to avoid red glare in your subject's eyes. The camera fires a brief, preflash flash before the regular flash.

NOTE:

- Red Eye  and Auto Flash  mode are not available if Macro  mode is selected. They are only available in Normal  mode.
- Never touch or block the flash with your fingers. Doing so can soil these components and interfere with correct flash operation.

● Setting Quick View

This setting enables you to view the picture immediately on the LCD screen right after it is taken. You can perform Quick View Setting in any camera mode.

1. Turn the camera on.
2. Press Menu button and use Right button to select "SETUP MENU .

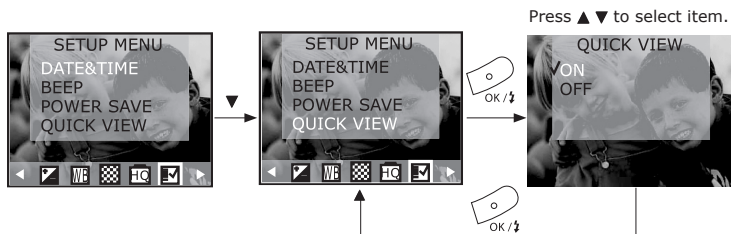

● Setting the Picture Resolution

Lower resolution is easier to email while high resolution and fine quality are for printing.

1. Set the Mode selector to Auto or Manual.
2. Turn the camera on.
3. Press Menu button and use Right button to select "RESOLUTION".

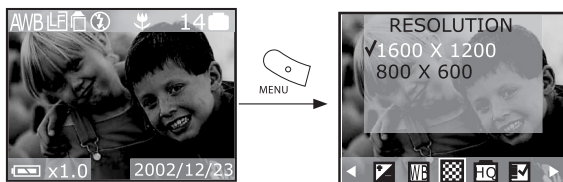

4. Press OK button to confirm and press Menu button to exit.

● Setting the Picture Quality

Smaller size pictures and normal quality are easier to email while larger size and fine quality are better for printing.

1. Set the Mode selector to Auto or Manual.
2. Turn the camera on.
3. Press Menu button and use Right button to select "QUALITY".
4. Use Up/Down button to set the quality of image compression.

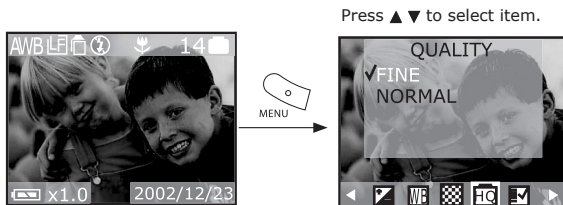

5. Press OK button to confirm and press Menu button to exit.

Here are the approximate number of pictures you can expect the camera to hold at each setting:

L 1600 X 1200	Fine:	Approx. 21 pictures
L 1600 X 1200	Normal:	Approx. 30 pictures
S 800 X 600	Fine:	Approx. 80 pictures
S 800 X 600	Normal:	Approx. 110 pictures

NOTE:

Scene complexity affects a picture's file size. For example, a picture of trees in autumn has a larger file size than a picture of blue sky at the same resolution and quality setting. Therefore, the number of pictures you can store on the camera internal memory or a memory card may vary. The number of pictures on the LCD screen is for reference only.

● Setting Self-timer

When you use the self-timer function, the subject is recorded about 2 or 10 seconds upon your setting after you press the shutter button.

1. Set the Mode selector to Auto or Manual.
2. Turn the camera on.
3. Press the Self-timer button.
Self-timer options:
No icon - Turns self-timer off.
⌚ - 2 SEC.(Press Self-timer one time) Indicates a countdown of two seconds.
⌚ - 10 SEC. Indicates a countdown of ten seconds.
4. Icon ⌚ (2 sec.) or ⌚ (10 sec.) appears on the LCD monitor, then press Shutter button.
5. The Self-Timer lamp will flash in red when you press Shutter button for countdown.
6. Press the Self-timer button again to cancel Self-timer.

● Digital zoom

This feature lets you “zoom” in on the central area of a picture and photograph only the enlarged portion of the picture. Digital zoom applies to only one picture at a time. If you want to use digital zoom again, press the digital zoom button.

When the LCD screen is on in Auto or Manual Mode, you can zoom in the subject before the image is taken.

1. Set Mode selector to Auto or Manual.
2. Turn on the LCD screen and the Information display on (if not, press Display button).
3. Press Up button to zoom in the subject.
4. Press Down button to zoom out the subject.
5. Press Shutter button to take picture.

● Setting Exposure Compensation

You can adjust the exposure compensation value (EV) within the range of -2EV to +2EV in order to compensate for current lighting conditions. This setting can be used to obtain better result when shooting with backlighting, indirect indoor lighting, a dark background, etc.

1. Turn on the camera.
2. Set the Mode selector to Manual.
3. Press Menu and use the Right button to select “EXPOSURE”.

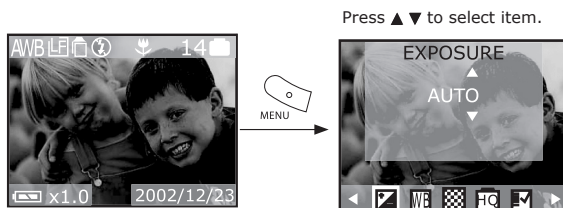

4. Press OK button to confirm and press Menu button to exit.

NOTE:

- A higher EV value is best used for dark-colored subjects and backlit subjects. A lower EV value is best for light-colored subjects and for shooting outdoors on a clear day.
- When shooting under very dark or very bright conditions, you may not be able to obtain satisfactory results even after performing exposure compensation.
- Exposure compensation returns to its standard default setting (AUTO) after you turn off and turn on the camera again.

● Setting White Balance

Selecting the right type of white balance can help to make the colours of a subject appear more natural under the type of lighting that is available.

1. Turn on the camera.
2. Set the Mode selector to Manual.
3. Press Menu and use the Right button to select “WHITE BALANCE (WB)”.
4. Use Up/Down button to select the white balance you need.

When shooting under these conditions:	Select this setting
Normal conditions (Camera adjusts white balance automatically.)	AUTO
Outdoor daylight	DAYLIGHT
Shade	SHADE
Indoors, illuminated by light bulbs	TUNGSTEN
Indoors, illuminated by fluorescent lighting	FLUORESCENT
Converts pictures to black and white	BLACK&WHITE

NOTE:

- White balance returns to its default setting (AUTO) after you turn off the camera and turn it on again.

4 Recording Video Clips

● Recording Video Clips

1. Set the Mode selector to Video mode.
2. Turn on the camera.
3. Frame your subject using the LCD screen.
4. Press Shutter button to start , if you want to stop, press the Shutter button again.

NOTE:

- In Video mode, you can record the video clip with audio.
- The resolution is set to 320x240 pixels.
- There is no zoom in and zoom out functions in Video mode.
- You can record video clip for up to approximately 70 seconds by using the internal memory.
- SD (Secure Digital)/MMC (MultiMediaCard) card increases the video recording time.

5 Playback Pictures and Video Clips

● Playback Pictures

Reviewing the pictures

1. Set the Mode selector to Playback.
2. Turn on the camera.
3. Press Left/Right button to view the pictures taken.

Zooming the displayed picture

When viewing a single image in Playback Mode, you can zoom the image you selected. The scale of zoom is from X1.0 to X4.0.

1. Set the Mode selector to Playback mode.
2. Turn on the camera.
3. Zoom the image up to the desired scale of zoom by using the Up button.
4. Press the Down button to zoom back the original full size image.

Reviewing the pictures in Thumbnail

You can view up to 9 pictures at a time by using the Thumbnail function.

1. Select the Mode selector to Playback mode.
2. Turn on the camera.
3. Press Display button, information display is off.
4. Press Display button again, the thumbnail display will highlight the image that had been showing at the time.



Running a slide show

View your pictures on the LCD screen by using the Slide Show feature. The pictures appear for a period of 5 sec. or 10 sec. upon the time you set.

1. Set the Mode selector to Playback mode.
2. Turn on the camera.
3. Press Menu button and use Right button to select "SLIDE SHOW".
4. Press Up/Down button to select the seconds you want the pictures to appear on the LCD screen.
OFF – The Slide Show feature is off (default setting).
5 sec. – The pictures will appear on LCD screen for a period of 5 seconds.
10 sec. – The pictures will appear on LCD screen for a period of 10 seconds.
5. Press OK button to complete your setting and start to run the slide show.
6. Press OK button to stop slideshow.

NOTE:

- The slide show will automatically run from the first picture taken after you press the OK button.
- You may stop the slide show by pressing any key.
- The slide show will keep running as long as there is power supply.
- Recommend using AC power for long time slide show.

● Playback the Video Clip

1. Set the Mode selector to Playback mode.
2. Turn on the camera.
3. Use Left/Right button to select the video clip you want to play.
4. Press OK button to start playing video clip, press OK button to pause or press Menu button to stop.

NOTE:

Icon "👤" is shown on LCD screen when video clip is selected.

● Protect the Picture(s) or Video Clip(s) Against Deletion

1. Set the Mode selector to Playback mode.
2. Turn on the camera.
3. Press Menu button and use Right button to select "PROTECT".

Protecting one picture or video clip

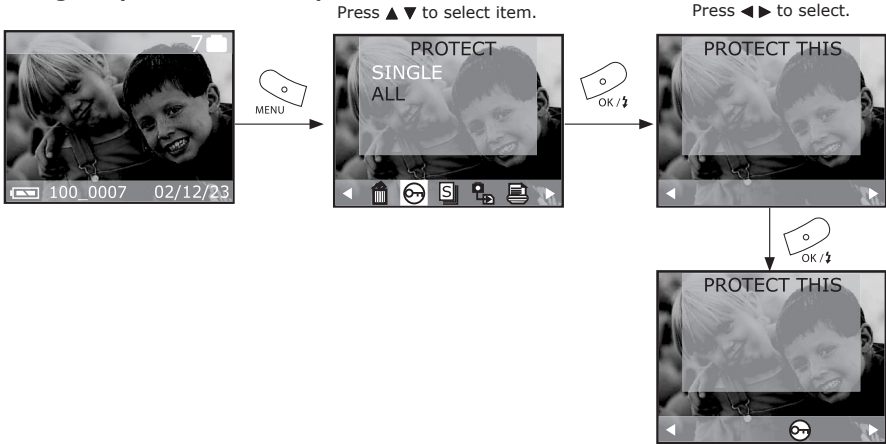

Protecting all pictures and video clips

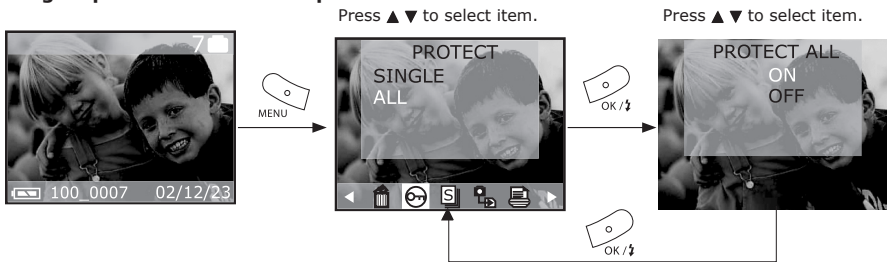

NOTE:

- Be sure that the PROTECT icon 🤪 appears after your setting.
- Use Left/Right button to slide the picture to the next one.

● Deleting Picture(s) or Video Clip(s) from the Camera

1. Set the Mode selector to Playback mode.
2. Turn on the camera.
3. Press Menu button and use Right button to select "DELETE" feature.

Deleting one picture or video clip

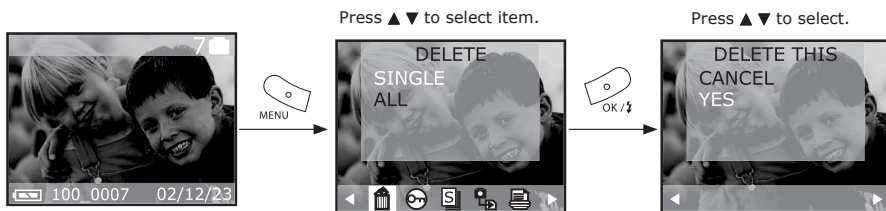

Press OK button to confirm, if you want to cancel deleting, select Cancel or press Menu button.

Deleting all pictures and video clips

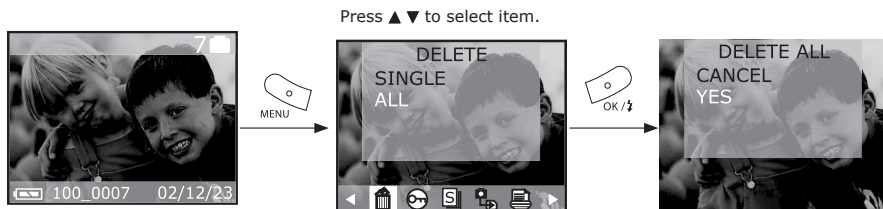

Press OK button to confirm, if you want to cancel deleting, select Cancel or press Menu button.

NOTE:
The protected file(s) cannot be deleted.

6 Using the Camera under Water

The waterproof case will allow you to use your camera in the rain, at the beach or on the ski slopes. You can also use it underwater at depths down to 30 metres (Maximum). Before you use the waterproof case, please make sure the case is functioning correctly and does not leak. Close the waterproof case before installing the camera and hold it underwater at an approximate depth of 15cm for several minutes to check for leaks. If it leaks, contact your customer support.

The buttons on waterproof case are as the same as on camera. For more details regarding the buttons, please refer to Page 2

For Safety/Handling Precautions for the waterproof case, please refer to section Tips, Your Safety & Maintenance.

- NOTE:**
- If images are taken underwater in dark environment, please switch the built-in flash light ON and then place the camera into the waterproof case.
 - Flash light underwater: effective distance 0.6 meter to 3.0 meter.
 - If the images are taken underwater in bright environment, we recommend the user not to switch on the built-in flash light, since it will affect the image quality.

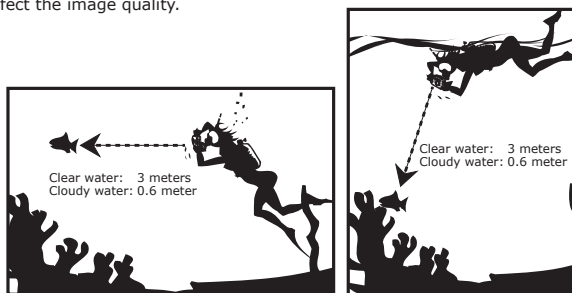

● Using the Rubber Ring

Please check the rubber ring before using. Check for any dirt, grains of sand, hair, dust, salt, thread scraps in the rubber ring and wipe off with a soft cloth or tissue paper.

Apply a coat of grease onto the rubber ring

- Apply a small drop of grease onto the rubber ring and evenly coat the entire surface of the rubber ring with the end of your finger.
- Do not use paper or cloth as fibre may stick to the rubber ring.
- Apply a thin and coating grease to the surface of the rubber ring, while grease can protect the rubber ring, also prevent water.
- Set the rubber ring immediately after you have applied a small drop of grease onto the rubber ring. Remember not to leave the greased rubber ring on a desk or other surface.

Place the rubber ring in the groove

Place the rubber ring evenly in its groove after applying a coat of grease. Please do not pull the rubber ring, make sure there is no dirt on the rubber ring, and the rubber ring is not protruding, twisted.

NOTE:

Please take a spare rubber ring with you. This enables you to replace when trouble occurs.

● Assemble Waterproof Case

1. Turn the camera off.
2. Secure unlock as seen on Diagram 1.

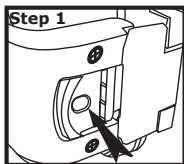

Unlock the waterproof case by pressing the safety lock button downward.

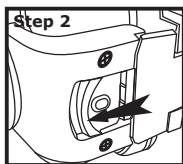

Open Hinge lock with arrow direction

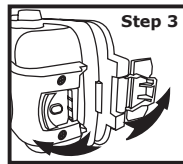

Open the waterproof case

Diagram 1

3. Place the camera into the waterproof case as illustrated in Diagram 2.
4. Secure lock as seen on Diagram 3.

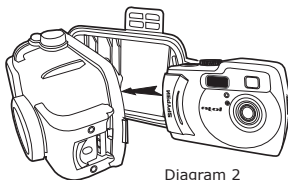
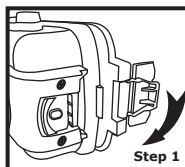
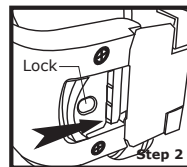

Diagram 2



Close the waterproof case completely



Push to lock

Diagram 3

7 Using SD/MMC Card

• Using the SD (Secure Digital) card or MMC (MultiMediaCard) card

Your camera comes with approximately 16MB of built-in flash memory for storing pictures/video clip. You can expand memory using a commercially available SD card/MMC card. The camera senses whether a memory card is inserted, and automatically saves pictures accordingly. Note that you cannot save pictures to built-in flash memory while a memory card is installed in the camera.

IMPORTANT!

- Make sure you turn off the camera before inserting or removing a memory card.
- Be sure to orient the card correctly when inserting it. Never try to force a memory card into the slot when you feel resistance.
- SD memory cards have a write protect switch, which you can use to protect against accidental deletion of picture data. "Whenever you want to record, format or delete item in the SD Card, you must disable write protection before any of above to action."

Inserting the SD (Secure Digital) card/MMC (MultiMediaCard) card

Turn off the camera and open the SD/MMC card slot cover as illustrated. Insert the SD card/MMC card, ensure the card is inserted the correct position as illustrated, close the card door before using the camera.

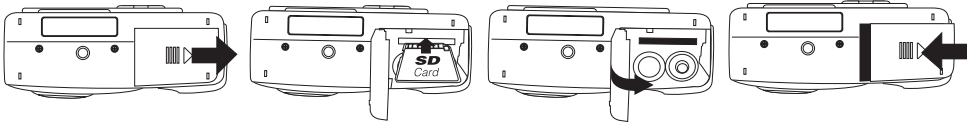

Removing the SD (Secure Digital) card/MMC (MultiMediaCard) card

To remove the SD/MMC card, turn off camera, open the SD/MMC card slot cover, gently push the SD/MMC card inwards and then release it for the SD/MMC card to bounce out of the SD/MMC card slot as illustrated.

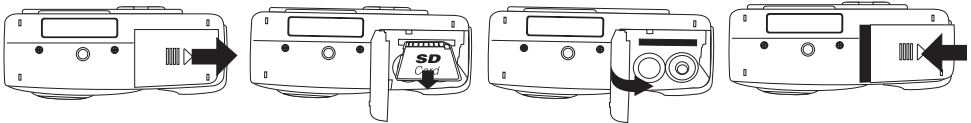

• To Format a Memory Card

Formatting a memory card deletes any data already stored on it.

1. Select the Mode selector to Playback mode.
2. Turn on the camera.
3. Press Menu button and use Right button to select "FORMAT".
Press ▲ ▼ to select item.



IMPORTANT!

- You can format a memory card on the camera or on a computer. However formatting a memory card on a computer takes much longer.
- Note that data deleted by a format operation cannot be recovered. Make sure you do not have any useful data currently stored on a memory card before you format it.
- Formatting a memory card destroys all the pictures, even those are protected.

After the memory storage is formatted, the message "NO IMAGE" appears on the camera LCD screen.

● Copy Internal Memory Pictures to a Memory Card

Turn off your camera and insert an SD (Secure Digital) Card/MMC (MultiMediaCard) into the Card Slot.

1. Set the Mode selector to Playback mode.
2. Turn on the camera.
3. Press Menu button and use Right button to select "COPY TO CARD".

Press ▲▼ to select item.



Memory Card Precautions

1. Use only a SD memory card or a MultiMediaCard with this camera. Proper operation is not guaranteed when any other type of card is used.
2. Electrostatic charge, electrical noise, and other phenomena can cause data corruption or even loss. Always make sure that you always back up important data on other media (MO disc, computer hard drive, etc.).
3. If a memory card starts to behave abnormally, you can restore normal operation by reformatting it. However, we recommend that you always take along more than one memory card whenever using the camera far away from the home or office.
4. We recommend that you format a memory card before using it for the first time after purchasing it, or whenever the card you are using seems to be the cause of abnormal pictures. Remember to format a memory card if it was used in another digital camera or other devices.

● DPOF (Digital Print Order Format)

The letters "DPOF" stand for "Digital Print Order Format", which is a format for recording on a memory card or other medium which digital camera images should be printed and how many copies of the image should be printed. Then you can print on a DPOF-compatible printer or at a professional print service from the memory card in accordance with the file name and number of copies settings recorded on the card.

With this camera, you should always select images by viewing them on the monitor screen. Do not specify images by file name without viewing the file contents.

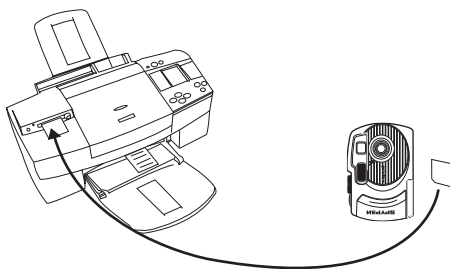

To print selected picture

1. Set the Mode to Playback mode.
2. Turn on the camera.
3. Press Menu button and use Right button to select "PRINT ORDER".

Press ▲▼ to select item.

Press ▲▼ to select item.

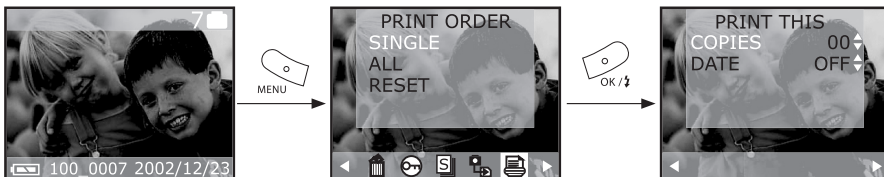

To print all pictures

1. Set the Mode selector to Playback mode.
2. Turn on the camera.
3. Press Menu button and use Right button to select "PRINT ORDER".

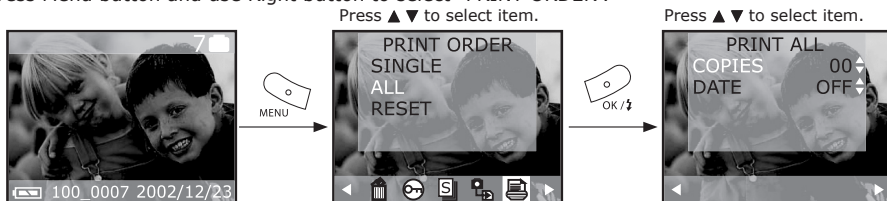

IMPORTANT!

DPOF print settings can be configured for images on a memory card only, not for images in the camera's built-in memory. To configure DPOF print settings for images in the camera memory, you first need to copy the images to a memory card.

● P.I.M. (PRINT Image Matching)

This camera supports PRINT Image Matching. Images recorded with it include information about the mode setting, camera setup, etc. When you print a picture on a printer that supports PRINT Image Matching, the printer reads this data and adjusts the printed image accordingly, so your image comes out just the way you intended when you recorded them. See the documentation that came with your printer for full details about PRINT Image Matching.

Now your digital camera and your printer can speak the same language.

PRINT Image Matching technology ensures that PRINT Image Matching-enabled digital cameras and printers work together perfectly to produce the best possible prints. Through this innovative technology, the printer is able to instantly identify the print specific information for each image captured, to provide superior colour, quality and detail in every print.

For more detailed information, please go to the PRINT Image Matching website <http://www.printimagema tching.com>.

8 Installing the Software onto a Computer

● Installing the Software

For Windows® Users:

PC

IMPORTANT!

- Please backup all the necessary data before any driver/software installation.
- Our CD-ROM is tested and recommended to use under English Window OS.

IMPORTANT! (For Windows® 98SE)

On Windows® 98SE Mass Storage function needs to install the ATOL Driver.

IMPORTANT! (For Windows® ME, 2000, XP)

Directly plug-in the camera to transfer and play the pictures and video clips, no need to install the driver.

IMPORTANT! - If the computer request you to install the Windows operating system during the software installation, place the Windows CD into the computer CD-ROM drive. The computer will install the necessary files from the CD automatically. When the Windows software appears to have finished the operation, close the Windows screen. Remove the Windows CD and store safely.

1. Before you begin, close all other software applications open on your computer.
2. Insert the CD supplied into the computer CD-ROM Drive.
3. The CD User Interface Screen will automatically launch.
4. With the mouse, click on each software interface button in turn and follow the on screen instructions.



NOTE:

If the setup screen doesn't appear after loading the CD, then you can manually start it by double-clicking the "My Computer" icon on your desktop, then double-clicking the icon for the CD-ROM drive. When the CD-ROM window opens, double-click the "INSTALL-E.EXE" icon.

For Macintosh® Users:

MAC

1. Before you begin, close all other software applications opened on your computer.
2. Insert the CD supplied into the computer CD-ROM Drive.
3. Double click the CD-ROM icon "My Digital Cam".
4. Install the software included.

● Software Included with Your Camera

ATOL Driver Plug & Play removable disk

Easy to use, just plug the camera to a computer and use it as a removable disk. Use the Arcsoft® software suite to edit and print the Pictures.

PhotoStudio® 4.0 Picture Editing Software

PhotoStudio® 4.0 is a full-featured, easy-to-use digital image-editing program that provides a complete set of photo editing and retouching tools, plus a wide selection of special effects and enhancements. Its powerful features include a wide variety of input and output options, layers, multiple undo and redo functions, image management tools, editable text, multiple file format support and a lot more.

For further help on how to use PhotoStudio® 4.0, go to "Help" to access the Help Topics.

Visit <http://www.arcsoft.com> for all your FAQ's, tips and technical support.

ArcSoft Funhouse™ 1.0 Picture Editing Software

ArcSoft Funhouse™ is an image entertainment application that enables users to create "photo fantasies" by combining their personal photos with a wide variety of fantasy backgrounds. Users can get their own images from digital cameras, scanners, disk drives and Photo CDs, and seamlessly combine them with just a few clicks of the mouse. The fantasy backgrounds include fictional characters, classic works of art, Olympic heroes, 50's funnies, bathing beauties, muscle men and a lot more.

For further help on how to use ArcSoft Funhouse™ 1.0, go to "Help" to access the Help Topics.

Visit <http://www.arcsoft.com> for all your FAQ's, tips and technical support.

ArcSoft PhotoPrinter® 2000 Picture Printing Software

ArcSoft PhotoPrinter® is an easy-to-use printing utility that enables the user to layout and print multiple images in different sizes quickly and easily on a single sheet of paper. The program offers a large selection of printing templates, including Kodak Digital Science Inkjet Photo Paper Templates and Avery-brand paper products. It also includes commonly used image-editing tools and a wide selection of templates for frames, edges and backgrounds for enhancing images.

For further help on how to use ArcSoft PhotoPrinter™ 2000, click the "?" on the top right hand corner to access the Help Topics.

Visit <http://www.arcsoft.com> for all your FAQ's, tips and technical support.

ArcSoft VideoImpression™ 1.6 Movie Making Software

ArcSoft VideoImpression™ is an easy-to-use video and image editing software program. The program enables users to create and edit new videos using existing video and image files - making desktop video presentations for home, business, and the Web.

Adobe® Acrobat® Reader .PDF File Reading Software

Adobe® Acrobat® Reader lets you view and print Adobe Portable Document format (PDF) files on all major computer platforms, as well as fill in and submit Adobe PDF forms online.

● Computer System Requirements

For acceptable picture transfer and editing, we recommend the following minimum requirements;

For Windows® Users

PC

- Compatible with Microsoft® Windows® 98SE, Me, 2000 or XP
- Pentium® II 333MHz or equivalent processor
- 64MB RAM (128MB recommended)
- USB Port
- 200MB free disk space
- Color monitor with high color (16-bit) graphic capability or higher
- CD-ROM drive
- Standard mouse and keyboard
- Stereo speakers

For Macintosh® Users

MAC

- PowerPC® Processor
- Mac™ OS Version 9.0, 9.0.4., 9.1
- USB Port
- 64MB RAM (128MB recommended)
- 150MB Free disk space
- Color monitor with high color (16-bit) graphic capability or higher
- CD-ROM drive
- Standard mouse and keyboard
- Stereo speakers

9 Transferring Pictures and Video Clips To Your Computer

• Before You Transfer Pictures

 **IMPORTANT!** - Before you transfer your pictures make sure you have installed the software from the CD.

Directory of folder and files

ATOL camera will create a directory of folders to store pictures automatically. A folder is created automatically whenever the first picture taken on one particular day, and the name of the folder is based on the date.

For example: 100_1204

- Day
- Month
- Underline
- Serial Number

Each folder can store up to 9,999 pictures. If you try to save 10,000th picture, a new folder will be created. The format of file name is "Month + Day + Serial Number". JPG

For Windows® and Macintosh® Users:



• Connecting to Your Computer

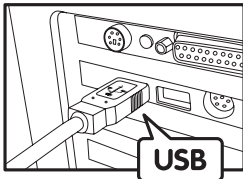

Connecting with the USB Cable.

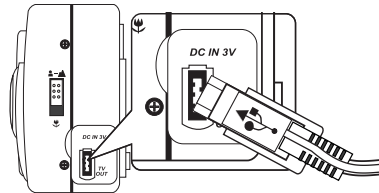

USB Series "A" Plug
Connects to your PC



USB Series "Mini B" Plug
Connects to your ATOL

1. Turn on the camera.
2. Plug the labelled end  of the USB cable into the socket marked  on your computer.
3. Plug the other end of the USB cable into the port on your camera.

• Transferring and Viewing the Pictures and Video clips



For Windows® Users:

1. Turn on the camera
2. Set the camera to Playback mode.
3. Connect the camera to a computer via the USB cable.
4. Open the Windows® Explorer and then you can see a "Removable Disk" drive.
5. Double click "Removable Disk" -> double click "DCIM"-> double click any directory folder under "DCIM".
6. All the pictures, video clips are in the directory folder. Highlight the pictures and video clips and drag them to a folder of your choice. You can also create sub folders to group them or use the Arcsoft software to edit and manage the pictures or video clips.

For Macintosh® Users:



 **NOTE:**
For MAC user, directly plug-in the camera, no need to install the driver.

1. Turn on the camera
2. Set the camera to Playback mode.
3. Connect the camera with MAC via USB cable, the systems will automatically recognize the MASS STORAGE drive. (System will automatically a Mass Storage named "INTERNAL"/"EXTERNAL")

-  **NOTE:**
This Drive name will vary from different version of MAC OS system.
4. Double click the folder "INTERNAL"/"EXTERNAL" to enter sub-folder "DCIM".
 5. Double click the folder "DCIM" to enter directory folder.
 6. You can copy the pictures and video clips from this directory folder and paste to the hard disk.

• Connecting to a TV

Pictures are displayed on the TV screen in either record or playback mode. When connected to a TV, the camera monitor is not active and all menu functions, pictures taken and pictures preview will be shown on the TV screen instead. The TV screen now performs as the camera monitor.

1. Use the video out cable to connect the camera to the television as shown in the illustration.
2. Set the TV to "Video" mode.
3. When the mode selector is switched to Auto/Manual, you can preview the picture you want to take.
4. When the mode selector switched to Playback mode, you can review all the pictures taken.

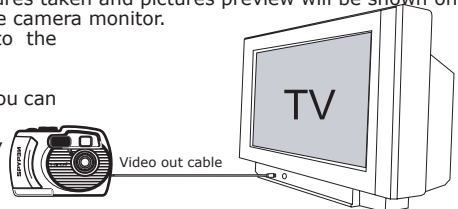

10 Troubleshooting Problems

The troubleshooting guide is designed to help you. If problems continue, please contact your local customer support hot-line. See your registration card for help line contact details.

Symptom	Problem	Solution
I receive an error message when I am installing "ATOL Camera Driver".	"ATOL Camera Driver" does not load.	Shut down all other applications and attempt to reinstall the driver. Check the USB controller in your BIOS if it is activated. If this does not work contact your national customer support representative.
I receive a message no image to download when I try to upload images to my computer.	Connection failure.	Check all cable connections are secured.
I cannot activate my Digital Camera by pressing the Power switch.	Insufficient battery power or batteries are missing.	Replace batteries.
My CD Installation wizard does not work.	The auto installation file is switched to off or The CD-ROM is disconnected.	Go to the computer desktop. Right click on "My Computer". Click "Properties". Select "Device Manager". Double click on "CD_ROM", double click on "CD-R (normally the manufacturer's name. click on "Settings". Ensure "Auto insert notification" is ticked and the "disconnect" is ticked. If you change the settings the computer will ask you to restart your PC. Click "Yes".
I cannot upload images to the Mac/	Connection failure.	Check all cable connections are secured.
Camera does not turn on.	Batteries are not oriented correctly or Batteries are dead or Wrong AC adaptor type being used.	Orient batteries correctly or Replace batteries or Make sure you use a correct adaptor.
Camera suddenly powers down.	Auto Power Function activated or Batteries are dead.	Turn power back on or Replace batteries.
Image is not recorded when the shutter button is pressed.	Camera is turned off or Flash unit is being charged or Memory is full.	Turn the camera on or Wait until flash unit charging finishes or Delete images you no longer need, or use another memory card.
Camera powers down during self-timer countdown.	Batteries are dead.	Replace batteries.
Monitor screen image is out of focus.	Macro Mode being used for scenery or portraits or Normal Mode being used for macro images.	Set the Normal/Macro selector to Normal for scenery and portraits or Set the Normal/Macro selector to Macro for macro images.
Recorded pictures are not saved in memory.	Camera powers off before the save operation is complete or Removing the memory card before the save operation is complete.	If the indicator is on the LCD screen, replace batteries with a full set of new ones as soon as possible or Do not remove the memory card before the save operation is complete.
Color of the playback pictures is different from the picture on the Monitor screen during recording.	Sunlight or light from another source is shining directly into the lens during recording.	Position the camera so sunlight does not shine directly onto the lens.
Pictures are not displayed.	A memory card with non-DCF pictures recorded with another camera is loaded in the camera.	This camera cannot display non-DCF pictures recorded onto a memory card used by another digital camera.
The picture selection screen does not appear when DELETE is selected.	All the pictures in memory are protected.	Unprotect the pictures you want to delete.
Monitor screen contents do not appear on the screen of a connected television.	There is a problem with the camera-TV connection or TV setup is wrong or Video system is incompatible.	Use the special video cable to connect the camera to the TV correctly or Consult the documentation of the TV and put it in its video mode or Select the proper video output system.

Please also refer to the help files & User Guides that accompany the enclosed applications. For further information and support, please visit our website: <http://www.spypen.com/>

11 Getting Help

● Online Services

Website: <http://www.spypen.com>

● Customer Support

plawa-feinwerktechnik GmbH & Co. KG

Bleichereistr. 18

73066 Uhingen - Germany

Helpline: +49 (7161) 93872-0 (English, Deutsch)

Website: www.spypen.com, www.plawa.de

Email: support@plawa.de

● ArcSoft Software Help

For North America

ArcSoft HQ Support Center

(Fremont California, CA)

Tel: 1-800-762-8657

(toll free number)

Fax: 1-510-440-1270

E-mail: support@arcsoft.com

For China

ArcSoft China Support Center (Beijing)

Tel: 8610-6849-1368

Fax: 8610-6849-1367

E-mail: china@arcsoft.com

For Oceania

ArcSoft Australian Support Center
(Baulkham Hills, New South Wales)

Tel: 61 (2) 9899-5888

Fax: 61 (2) 9899-5728

E-mail: support@supportgroup.com.au

For South & Central America

Tel: 1-510-979+5520

Fax: 1-510-440-1270

E-mail: latlnsupport@arcsoft.com

For Japan

ArcSoft Japan Support Center (Tokyo)

Tel: +81-03-3834-5256

Fax: +81-03-5816-4730

Web: <http://www.mds2000.co.jp/arcsoft>

E-mail: japan@arcsoft.com and
support@mds2000.com

For Europe/Middle East/ Africa & Rest of the World

ArcSoft Europe Support Center
(Ireland)

Tel: +353-(0) 61-702087

Fax: +353-(0) 61-702001

E-mail: europe@arcsoft.com

Visit <http://www.arcsoft.com> for technical support and frequently asked questions (FAQ's).

● Technical Specifications

- Internal Memory: 16MB NAND FLASH
- External Memory: support SD/MMC card memory card up to 128MB (not included)
- Still Image Resolution (based on 16 MB internal memory)
 - Fine quality - 1600 x 1200 pixel - Approx. 21 pictures
800 X 600 pixel - Approx. 80 pictures
 - Normal quality - 1600 x 1200 pixel - Approx. 30 pictures
800 X 600 pixel - Approx. 110 pictures
- Still Image Quality:
 - Fine - 5X compression rate
 - Normal - 8X compression rate
- Video Resolution: 320 x 240 pixel
- Self Timer:
 - 2 or 10 seconds with Beep sound
- Video Clip:
 - Unlimited when connected to the computer via USB
 - Limited when using the internal memory: @ 320 X 240 pixel, 14fps, Approximately 150s with 16M internal memory
- Playback Mode: Single/9 Thumbnail pictures
- File Format:
 - Still Image - Still & Burst: EXIF 2.2 compatible format (JPEG compression)
DCF compatible. Support DPOF, PIM
 - Video Clip - AVI format
- Image Deletion
 - Single image; all images in memory (with image protection); Format
- Lens Module
 - Element: 5 Glass
 - F=6.21 mm F/3.3, F/8 (equivalent to 48mm lens for 35mm film)
- Zoom
 - Capture Mode: ~ X3 continuous 0.2X/step
 - Playback Mode: ~ X4 continuous, 0.1X/step
- Focusing
 - Fixed focus with macro mode
- Focus Range
 - Normal focus: 12" to ∞ (30cm to ∞)
 - Macro focus: 8" (20cm)
(The focusing range is the distance from the lens surface to the subject)
- Built-in Flash
 - Flash Modes - AUTO, OFF, ON, Red-eye reduction
 - Flash Range - 3.0m
- Video Out
 - NTSC/PAL
- Low Battery indicator
 - 2 levels, Full / Low and Exhausted
- Weight
 - Approximately 150g (6.7 oz) excluding batteries
- External Connector: USB, SD/MMC card slot
- Auto Power Off: 1 minutes after power saving
- Power Saving: User setting, in Capture/Playback mode with battery power in (OFF/1 min/3 min)
- Monitor
 - 1.5" TFT colour panel with LED back light
- Input/Output Terminal
 - USB port (Mini-B port), AC adaptor connector, Video Out (NTSC/PAL)
- Power Supply
 - USB Port
 - 2 x AA Alkaline Batteries (included)
 - +3.3V DC Adaptor (not included)
- Operating System:
 - For Windows® Users: Microsoft® Windows® 98SE, ME, 2000 or XP
 - For Macintosh® Users: Mac® OS Version 9.0, 9.0.4, 9.1
- Waterproof Case
 - Depth underwater: 30 metres (Maximum)

● Using your batteries

IMPORTANT NOTE:

A fresh alkaline battery provides an output voltage of 1.5V whereas a rechargeable battery available in retail stores generally has a lower output 1.2V. In order to maximize the performance of your **ATOL camera**, we recommend that you do not use rechargeable batteries.

WARNINGS!

- Batteries should be replaced by an adult.
 - Do not mix different types of batteries or new and used batteries.
 - Use recommended or equivalent type of batteries only.
 - Insert the batteries with the correct polarity.
 - Remove exhausted batteries from the camera immediately.
 - Do not short the supply terminals.
 - Do not dispose the batteries in fire.
 - Remove batteries from the camera when not in use.
 - Rechargeable batteries are not recommended.
- These instructions should be retained for future reference.

● Tips, Your Safety & Maintenance

Your Camera should only be operated within the following environmental conditions;

- 41 - 104° Fahrenheit; 5 - 40° Celsius
- 20% - 85% relative humidity, non condensing

Battery life or image quality may be affected outside these conditions

Camera Cautions

- NEVER immerse any part of the Camera or its accessories into any fluid or liquid.
- ALWAYS disconnect the Camera from your PC or TV before cleaning it.
- ALWAYS remove dust or stains with a soft cloth dampened with water or neutral detergent.
- NEVER place hot items on the surface of the Camera.
- NEVER attempt to open or disassemble Camera as this will affect any warranty claim.

Waterproof Case Precautions

Safety

- Do not use the waterproof case in place of a personal floatation device (life jacket).
- Do not use the waterproof case at water depths exceeding 10 meters. The case may malfunction, suffer damage or leak.
- When cleaning the case, do not spray water at it under pressure. This may cause leaks.
- Do not disassemble or modify the waterproof case. This may cause leaks.
- Do not damage the waterproof seal, scratch its contact surfaces, or allows dirt to accumulate between the waterproof seal and the case. This may cause leaks.
- Do not use the waterproof case in water at temperatures above 40°C (104°F). Heat may warp it or cause leaks.
- Do not leave the waterproof case in direct sunlight, inside a car in hot weather, or near a heater. Heat may warp the casing and cause leaks. Cover it with a towel, for example, if you have to leave it in the sun.

Handling

- Do not drop or throw the waterproof case.
- Avoid opening or closing the waterproof case near water.
- Avoid using the waterproof case for long periods of time in hot temperatures.
- Moving the waterproof case rapidly between hot and cold temperatures may cause condensation (water droplets) to form on its external and internal surfaces. Condensation may cause malfunctions. You can avoid this by placing the waterproof case in airtight plastic bag and letting it adjust to temperature changes slowly before removing it from the bag. Stop using the camera immediately if you detect condensation, wipe off the condensation from the waterproof case and the camera with a soft, dry cloth, and wait until the moisture evaporates completely before resuming use.
- After you use the waterproof case, be sure to remove the **ATOL** from it. If you leave the waterproof case with the **ATOL** still inside in direct sunlight or in a high-temperature place, this may cause a fire or bursting.
- After use, be sure to dry all water from the waterproof case completely.
- Remove any salt, dirt, sand, or other particles from the waterproof case, and wash it with clean, running tap water. Keep the waterproof case locked while washing it.

Storage

- To keep the waterproof case in good condition during storage, do not fasten the catch after closing the waterproof case.
- Protect the waterproof case from dust or scratches during storage.
- Do not store the waterproof case in hot, cold or humid places, or near substances such as naphthalene or insecticides.

NOTE:
The following driver uninstall procedure is for Windows 98SE user only because only Windows 98 needs to install the ATOL driver.

1. Open **Add/Removable Program Properties** in Control Panel and select ATOL program, then click **Add/Remove**.
2. The following dialog box appears, and click **Yes** to confirm removing camera driver.
3. The un-installation program runs automatically, please restart your computer when it is finished.
4. Ok, the driver un-installation is completed.

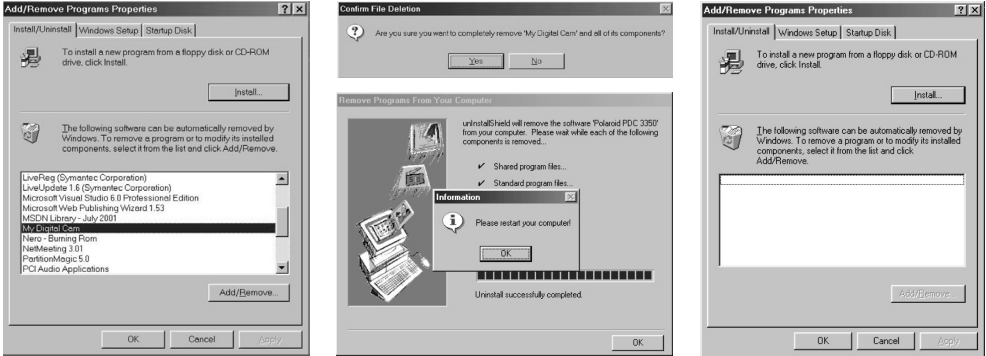

● **Regulatory Information**
FCC Notice

This device complies with Part 15 of FCC Rules. Operation is subject to the following two conditions: (1) This device may not cause harmful interference, and (2) This device must accept any interference received, including interference that may cause undesired operation.

Warning: Changes or modifications to this unit not expressly approved by the party responsible for compliance could void the user's authority to operate the equipment.

NOTE: This equipment has been tested and found to comply with the limits for Class B digital device, pursuant to Part 15 of the FCC Rules. These limits are designed to provide reasonable protection against harmful interference in a residential installation. This equipment generates, uses and can radiate radio frequency energy and, if not installed and used in accordance with the instructions, may cause harmful interference to radio communications.

However, there is no guarantee that interference will not occur in a particular installation. If this equipment does cause harmful interference to radio or television reception, which can be determined by turning the equipment off and on, the user is encouraged to try to correct the interference by one or more of the following measures:

- Reorient or relocate the receiving antenna.
- Increase the separation between the equipment and receiver.
- Connect the equipment into an outlet on a circuit different from that to which the receiver is needed.
- Consult the dealer or an experienced radio/TV technician for help.

Shielded cable must be used with this unit to ensure compliance with the Class B FCC limits.

Under the environment with electrostatic discharge, the product may malfunction and require user to reset the product.